



日野700

38噸拖頭 24/30噸泥車
30噸混凝土車 24/30噸貨車

EURO 6



行業
專家

日野
Total
Support

實踐車輛
100%
可用時間

減低
操作成本

日野與環保 **EURO 6**

環保商用車輛
Environment-friendly
Commercial Vehicle

日野貨車引擎排放比歐盟六型標準低平均約80%，
能更嚴謹地改善空氣質素。



日野貨車專家團隊

每一輛日野商用車都堅守兩大原則

實踐車輛的100%營運時間

減低操作成本

適用於2020年3月31日或之前登記，並
獲環保署審批確認為《環保商用車輛》，
可享首次登記稅寬減達50%。

香港日野銷售服務團隊由貨車專家組成，具備豐富貨車
知識及行業資訊為客人設計最合適的搵食車



卓越駕駛功能



符合人體工學設計駕駛室

減輕駕駛疲勞，提升安全性

ISRI氣壓減震司機座椅及全浮式駕駛室空氣懸掛系統

預索式三點式安全帶及駕駛席安全氣袋
為司機帶來最周全保障

門邊腳踏及扶手
方便司機由駕駛室移動至車斗操控位置



門邊腳踏



門頂扶手



預索式三點式安全帶



全新SCR 3.0

新DPF微粒收集系統
自動或手動清洗廢氣鼓延長SCR系統壽命

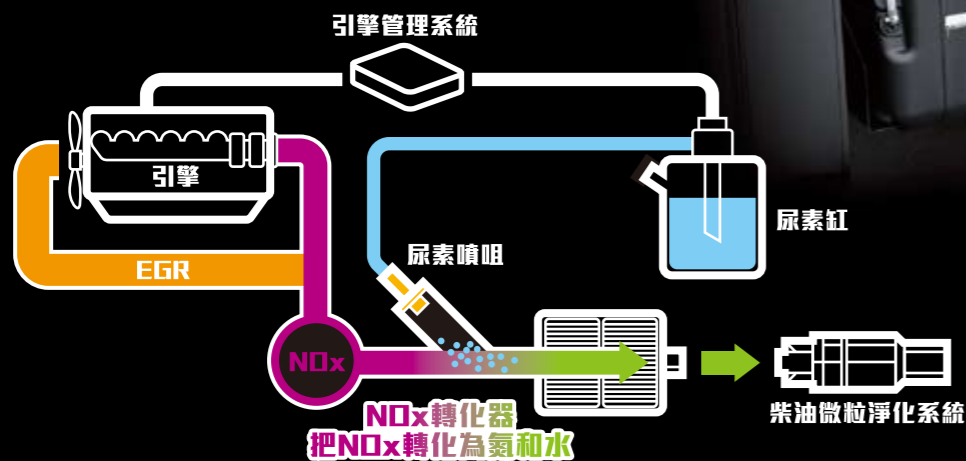

易上手駕駛系統

全線備有享負盛名的7前速手動波箱及

德國ZF16前速AMT自動波箱

可供選擇

操作簡單，可靠耐用

三段式RET引擎輔助制動系統

加強煞車效能，無懼緊急情況，
行車安全可靠



16前速AMT
自動波箱



7前速
手動波箱



強化車陣。裝斗快捷

“Straight Frame” 車陣

堅固而輕巧的車架令載重量大大提升
全平面車陣及預設多組鑽孔，縮短裝斗時間，
更快投入運作



穩定避震系統

前軸特強龍船葉片式陣弓連吸震筒及穩定桿
後軸電子控制氣壓式避震系統
*指定型號

歐盟六型新引擎動力增加

E13C-AT引擎扭力更強更早
出現，搵食更爽手

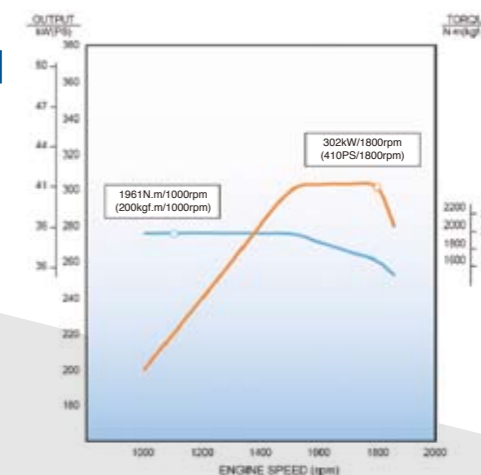

日野貨車。助您搵食

慳錢

波箱可靠耐用，減少維修支出
自動波容易操作，減低司機培訓成本

慳時

全新車陣佈局配以原廠鑽孔，令裝斗更快捷順暢，
更快投入運作

60分鐘專業「特快」維修檢查服務

*只限行車里數低於30,000公里的日野車系享用。
若有其他維修項目跟進，需要額外維修時間

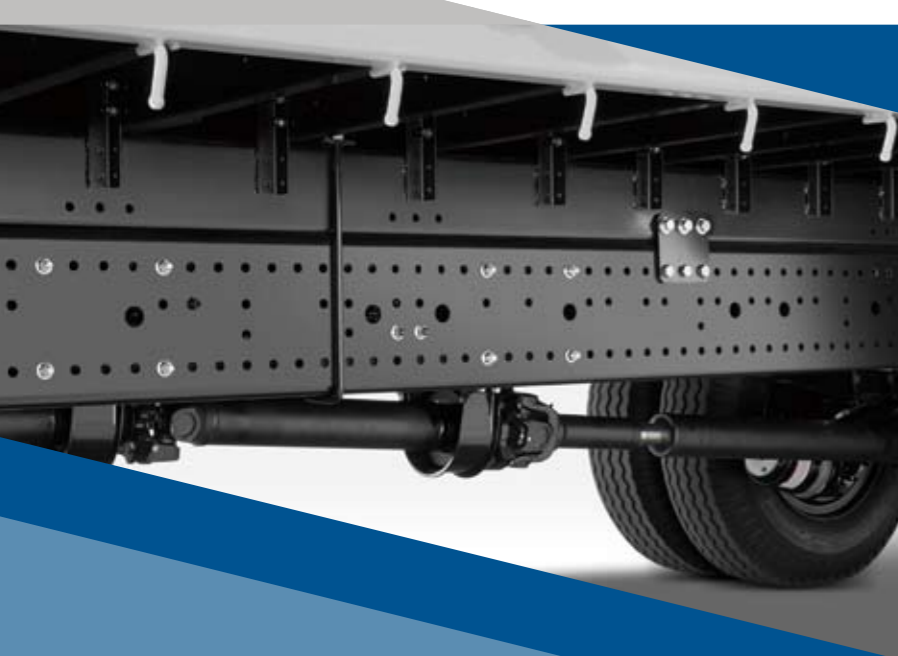

HINO
Express 特快維修
Maintenance

HINO 日野 700 拖頭

Emission Standard 廢氣排放標準	EURO VI 環保六型拖頭			
Model 型號	HINO 72041 (SH1EEMA-KAG)	HINO 72041 (SH1EEMA-MXG)	HINO 72041 (SH1EEMG-MXG)	
G.V.W. 總重量 (kg 公斤)	16,000	16,000	16,000	
G.C.W. 總組合重量 (kg 公斤)	38,000	38,000	38,000	
Axle Capacity 車軸載重量 (kg 公斤)	1st Axle 第一軸	7,100	7,100	
	2nd Axle 第二軸	10,000	10,000	
Dimensions 車身尺寸 (mm 毫米)	Overall Length 總長度 OL	5,785	5,785	
	Overall Height 總高度 OH	3,010	3,010	
	Cab Width 駕駛室闊度 CW	2,490	2,490	
	Wheelbase 輪距 WB	3,330	3,330	
	Rear Overhang 尾懸出量 ROH	1,075	1,075	
	Fifth Wheel Height 磨盤高度 FWH	1,300	1,235	
	Rear Axle Width 後軸闊度 RW	2,450	2,450	
Engine 引擎	Model 型號	E13C-AT	E13C-AT	
	Type 類別	Diesel Engine, In-line 6-cylinder, Variable Geometry Turbo (VGT) Charger and Intercooler, Exhaust Gas Recirculation (EGR) System 柴油引擎, 直列式六汽缸, 可變活瓣渦輪增壓連中置冷卻器, 廢氣再循環系統		
	Capacity 汽缸容積 (cc 毫升)	12,913		
	Max. Output 最大馬力 (JIS) (PS/rpm 匹/轉)	410 / 1,500 - 1,800		
	Max. Torque 最大扭力 (JIS) (公斤-米轉 kgf.m/rpm)	200 / 1,000 - 1,400		
Transmission Type 傳動系統	Type 類別	7 Forward & 1 Reverse Speeds, Synchromesh 2nd-6th Gears with Power Shift 七前速及一後速, 二至六波同步齒合式及動力輔助	ZF 16 Forward & 2 Reverse Speeds, Automated Transmission ZF 十六前速及二後速, 自動變速箱	
	Gear Ratio 齒輪比例	6.230 - 0.595	14.120 - 0.827	
	Rear Axle Gear Ratio 尾牙比例	5.428	3.727	
Brake System 制動系統	Service Brake 行車制動	Full Air, Dual Circuit, Wedge Type, Leading & Trailing Shoes for Front & Rear with Auto Brake Shoes Adjuster, ABS 雙迴路全風模式制動, 配合領從式制動蹄片及剎車皮虛位自動調校器, ABS防鎖剎車系統		
	Parking Brake 泊車制動	Spring Brake, Action on Front and Rear Wheels 彈簧制動頭及尾輪		
	Auxiliary Brake 輔助制動	Engine Retarder & Trailer Brake 引擎制動及拖架制動系統		
Suspension System 懸掛系統	Front 前軸	Semi-Elliptic Tapered Leaf Springs with Shock Absorbers & Stabilizer 半橢圓彈簧片附吸震筒及穩定桿		
	Rear 後軸	Semi-Elliptic Main & Auxiliary Leaf Springs with Shock Absorbers 半橢圓彈簧片及輔助彈簧片附吸震筒	Air Suspension 2 Bellows with Shock Absorbers & Stabilizer 氣墊式避震2氣袋附吸震筒及穩定桿	
Performance 性能	Gradeability at G.V.W. 爬坡度 (tan)	27.5%	46.1%	
Tire 輪呔		295 / 80 R22.5		
Fuel Tank Capacity 油缸容量		330 (鋁合金Aluminium)		
Standard Equipment 標準裝置	HID Headlamp with Auto Headlamp Leveling & Washer 高亮度放射式車頭燈連自動角度調校及清洗裝置 Spoiler Type Front Bumper 擾流式前泵把 Driver Seat Airbag 司機位安全氣袋 ISRI Auto Adjustable Air Suspension Driver Seat ISRI自動調節氣墊避震司機座椅 Factory Installed Air-Conditioner (R134A) 原廠安裝R134A環保冷暖氣系統 CD Player & AM / FM Radio 鑄射唱碟機及AM/FM收音機 Sleeping Bed with Wrap-around Curtain 睡床連全包围式窗簾 Electrical Tilttable Air Suspension Driver Cab 電動起揚式氣墊避震全浮式駕駛室 Power Windows & Central Door Lock 電動車窗及中央門鎖 Power Mirror Stay 電動摺鏡 Remote Control & Heater Mirrors 電動調校及發熱線倒後鏡 Power Steering 動力輔助轉向系統 Energy Absorbing Steering Wheel 吸撞式軟盤 Collapsible Steering Column 緩衝式軟盤柱 Door Side Impact Beam 車門強化防撞桿 24V-60A Alternator 24伏特-60安培發電機 150Ah Batteries 150安培小時電池 DPR & SCR System 柴油微粒淨化系統及選擇性催化還原器 28L Adblue Tank 28升尿素缸 Aluminium Air Tanks 鋁合金風缸 Trailer Connector and Coupler 拖架接駁器及磨盤			

HINO 日野 700 泥車陣 / 混凝土車陣

Emission Standard 廢氣排放標準	EURO VI 環保六型泥車陣		EURO VI 環保六型混凝土車陣	
Model 型號	HINO 72841 (FS1ELMD-KAG)	HINO 73241 (FY1ETMD-KAG)	HINO 73441 (FY1ETNM-KAS)	
G.V.W. 總重量 (kg 公斤)	24,000	30,000	30,000	
Axle Capacity 車軸載重量 (kg 公斤)	1st Axle 第一軸	7,100	7,100	
	2nd Axle 第二軸	9,000	7,100	
	3rd Axle 第三軸	9,000	9,000	
	4th Axle 第四軸	-	9,000	
Dimensions 車身尺寸 (mm 毫米)	Overall Length 總長度 OL	7,645	8,845	
	Overall Height 總高度 OH	3,035	3,065	
	Cab Width 駕駛室闊度 CW	2,490	2,490	
	Wheelbase 輪距 WB	3,630 + 1,350	1,850 + 3,130 + 1,350	
	Cab to Rear Axle 駕駛室後至後軸 CA (mm 毫米)	3,630	4,980	
	Rear Overhang 尾懸出量 ROH (mm 毫米)	1,960	1,810	
	Chassis Frame Height 陣尾高度 FH (mm 毫米)	1,142	1,125	
	Rear Axle Width 後軸闊度 RW (mm 毫米)	2,450	2,450	
	Model 型號	E13C-AT	E13C-AT	E13C-AT
	Type 類別	Diesel Engine, In-line 6-cylinder, Variable Geometry Turbo (VGT) Charger and Intercooler, Exhaust Gas Recirculation (EGR) System 柴油引擎, 直列式六汽缸, 可變活瓣渦輪增壓連中置冷卻器, 廢氣再循環系統		
Capacity 汽缸容積 (cc 毫升)	12,913			
Max. Output 最大馬力 (JIS) (PS/rpm 匹/轉)	410 / 1,500 - 1,800			
Max. Torque 最大扭力 (JIS) (公斤-米轉 kgf.m/rpm)	200 / 1,000 - 1,400			
Transmission Type 傳動系統	Type 類別	7 Forward & 1 Reverse Speeds, Synchromesh 2nd-6th Gears with Power Shift 七前速及一後速, 二至六波同步齒合式及動力輔助		
	Gear Ratio 齒輪比例	6.230 - 0.595		
	Rear Axle Gear Ratio 尾牙比例	6.428		
Brake System 制動系統	Service Brake 行車制動	Full Air, Dual Circuit, Wedge Type, Leading & Trailing Shoes for Front & Rear with Auto Brake Shoes Adjuster, ABS 雙迴路全風模式制動, 配合領從式制動蹄片及剎車皮虛位自動調校器, ABS防鎖剎車系統		
	Parking Brake 泊車制動	Spring Brake, Action on 1st & 2nd 彈簧制動第一軸及第二軸	Spring Brake, Action on 3rd & 4th 彈簧制動第三軸及第四軸	
	Auxiliary Brake 輔助制動	Engine Retarder, Exhaust Brake & Easy Smooth Start (ESS) System 引擎制動系統, 廢氣制動及ESS輔助起步系統		
Suspension System 懸掛系統	Front 前軸	Semi-Elliptic Tapered Leaf Springs with Shock Absorbers & Stabilizer 半橢圓彈簧片附吸震筒及穩定桿		
	Rear 後軸	Semi-Elliptic Leaf Springs with 2nd & 3rd axle Shock Absorbers 半橢圓彈簧片附第二軸及第三軸吸震筒	Semi-Elliptic Leaf Springs with 2nd & 3rd axle Shock Absorbers 半橢圓彈簧片附第二軸及第三軸吸震筒	Semi-Elliptic Leaf Springs 半橢圓彈簧片
Performance 性能	Gradeability at G.V.W. 爬坡度 (tan)	59.1%	50.2%	46.5%
Tire 輪呔		12 R22.5		295 / 80 R22.5
Fuel Tank Capacity 油缸容量		330 (金屬Steel)		210 (金屬Steel)
Standard Equipment 標準裝置	Spoiler Type Front Bumper 擾流式前泵把 Driver Seat Airbag 司機位安全氣袋 ISRI Auto Adjustable Air Suspension Driver Seat ISRI自動調節氣墊避震司機座椅 Factory Installed Air-Conditioner (R134A) 原廠安裝R134A環保冷暖氣系統 CD Player & AM / FM Radio 鑄射唱碟機及AM/FM收音機 Sleeping Bed with Wrap-around Curtain 睡床連全包围式窗簾 Electrical Tilttable Air Suspension Driver Cab 電動起揚式氣墊避震全浮式駕駛室 Power Windows & Central Door Lock 電動車窗及中央門鎖 Power Mirror Stay 電動摺鏡 Remote Control & Heater Mirrors 電動調校及發熱線倒後鏡 Power Steering 動力輔助轉向系統 Energy Absorbing Steering Wheel 吸撞式軟盤 Collapsible Steering Column 緩衝式軟盤柱 Door Side Impact Beam 車門強化防撞桿 24V-60A Alternator 24伏特-60安培發電機 150Ah Batteries 150安培小時電池 DPR & SCR System 柴油微粒淨化系統及選擇性催化還原器 28L Adblue Tank 28升尿素缸 Aluminium Air Tanks 鋁合金風缸			

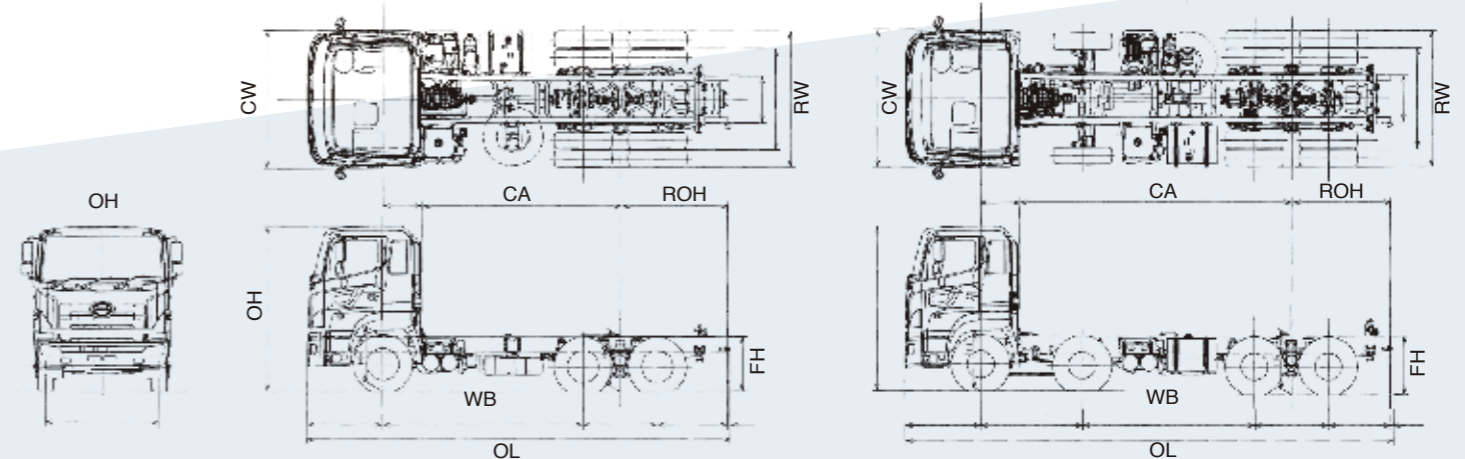
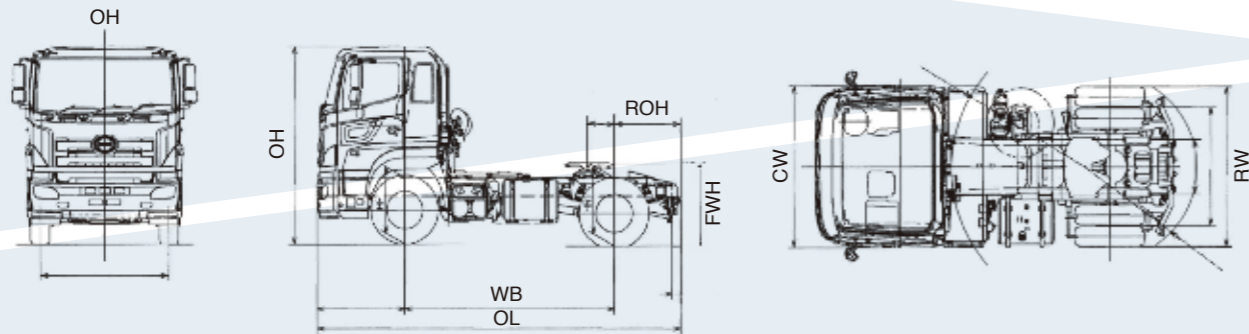

備註：(1)引擎符合香港現行廢氣及噪音管制條例, 詳情請向本公司營業員查詢。(2)有關引擎性能及耗油量資料, 可向陳列室查詢。
(3)規格如有更改, 恕不另行通知。(4)本產品簡介所載之圖片可能與本港出售之型號有差別之處。 *適用於主要組件, 詳情請參閱維修保用證明手冊。



HINO 日野 700 貨車陣

Emission Standard 廢氣排放標準		EURO VI 環保六型貨車陣				EURO VI 環保六型貨車陣				
Model 型號		HINO 72841 (FS1ESMA-KAG)	HINO 72841 (FS1ESMA-MXG)	HINO 72841 (FS1EUMA-KAG)	HINO 72841 (FS1EUMA-MXG)	HINO 72841 (FS1ESMG-MXG)	HINO 72841 (FS1EUMG-MXG)	HINO 73241 (FY1EUMA-KAG)	HINO 73241 (FY1EUMA-MXG)	HINO 73241 (FY1EUMG-MXG)
G.V.W. 總重量	(kg 公斤)	24,000	24,000	24,000	24,000	24,000	24,000	30,000	30,000	30,000
Axle Capacity 車軸載重量	1st Axle 第一軸 (kg 公斤)	7,100	7,100	7,100	7,100	7,100	7,100	7,100	7,100	7,100
	2nd Axle 第二軸 (kg 公斤)	9,000	9,000	9,000	9,000	9,000	9,000	7,100	7,100	7,100
	3rd Axle 第三軸 (kg 公斤)	9,000	9,000	9,000	9,000	9,000	9,000	9,000	9,000	9,000
	4th Axle 第四軸 (kg 公斤)	-	-	-	-	-	-	9,000	9,000	9,000
Dimensions 車身尺寸	Overall Length 總長度 OL (mm 毫米)	10,095	10,095	10,895	10,895	10,095	10,895	10,695	10,695	10,695
	Overall Height 總高度 OH (mm 毫米)	3,015	3,015	3,015	3,015	3,015	3,015	3,045	3,045	3,050
	Cab Width 駕駛室闊度 CW (mm 毫米)	2,490	2,490	2,490	2,490	2,490	2,490	2,490	2,490	2,490
	Wheelbase 輪距 WB (mm 毫米)	4,830 + 1,350	4,830 + 1,350	5,280 + 1,350	5,280 + 1,350	4,855 + 1,325	5,305 + 1,325	1,850 + 3,430 + 1,350	1,850 + 3,430 + 1,350	1,850 + 3,455 + 1,325
	Cab to Rear Axle 駕駛室後至後軸 CA (mm 毫米)	4,830	4,830	5,280	5,280	4,840	5,290	5,280	5,280	5,290
	Rear Overhang 尾懸出量 ROH (mm 毫米)	3,210	3,210	3,560	3,560	3,198	3,548	3,360	3,360	3,348
	Chassis Frame Height 陣尾高度 FH (mm 毫米)	1,130	1,129	1,131	1,131	1,081	1,082	1,114	1,114	1,060
	Rear Axle Width 後軸闊度 RW (mm 毫米)	2,450	2,450	2,450	2,450	2,470	2,470	2,450	2,450	2,470
Engine 引擎	Model 型號	E13C-AT	E13C-AT	E13C-AT	E13C-AT	E13C-AT	E13C-AT	E13C-AT	E13C-AT	E13C-AT
	Type 類別	Diesel Engine, In-line 6-cylinder, Variable Geometry Turbo (VGT) Charger and Intercooler, Exhaust Gas Recirculation (EGR) System 柴油引擎, 直列式六汽缸, 可變活瓣渦輪增壓連中置冷卻器, 廢氣再循環系統				Diesel Engine, In-line 6-cylinder, Variable Geometry Turbo (VGT) Charger and Intercooler, Exhaust Gas Recirculation (EGR) System 柴油引擎, 直列式六汽缸, 可變活瓣渦輪增壓連中置冷卻器, 廢氣再循環系統				
	Capacity 汽缸容積 (cc 毫升)	12,913				12,913				
	Max. Output 最大馬力 (JIS) (PS/rpm 匹/轉)	410 / 1,500 - 1,800				410 / 1,500 - 1,800				
Transmission 傳動系統	Type 類別	7 Forward & 1 Reverse Speeds, Synchronesh 2nd-6th Gears with Power Shift 七前速及一後速, 二至六波同步齒合式及動力輔助	ZF 16 Forward & 2 Reverse Speeds, Automated Transmission ZF 十六前速及二後速, 自動變速箱	7 Forward & 1 Reverse Speeds, Synchronesh 2nd-6th Gears with Power Shift 七前速及一後速, 二至六波同步齒合式及動力輔助	ZF 16 Forward & 2 Reverse Speeds, Automated Transmission ZF 十六前速及二後速, 自動變速箱	ZF 16 Forward & 2 Reverse Speeds, Automated Transmission ZF 十六前速及二後速, 自動變速箱	7 Forward & 1 Reverse Speeds, Synchronesh 2nd-6th Gears with Power Shift 七前速及一後速, 二至六波同步齒合式及動力輔助	ZF 16 Forward & 2 Reverse Speeds, Automated Transmission ZF 十六前速及二後速, 自動變速箱	ZF 16 Forward & 2 Reverse Speeds, Automated Transmission ZF 十六前速及二後速, 自動變速箱	ZF 16 Forward & 2 Reverse Speeds, Automated Transmission ZF 十六前速及二後速, 自動變速箱
	Gear Ratio 齒輪比例	6.230 - 0.595	14.120 - 0.827	6.230 - 0.595	14.120 - 0.827	14.120 - 0.827	6.230 - 0.595	14.120 - 0.827	14.120 - 0.827	14.120 - 0.827
	Rear Axle Gear Ratio 尾牙比例	6.142	4.100	6.142	4.100	4.100	6.142	4.100	4.100	4.100
Brake System 制動系統	Service Brake 行車制動	Full Air, Dual Circuit, Wedge Type, Leading & Trailing Shoes for Front & Rear with Auto Brake Shoes Adjuster, ABS 雙迴路全風模式制動, 配合領從式制動蹄片及剎車皮虛位自動調校器, ABS防鎖制車系統				Full Air, Dual Circuit, Wedge Type, Leading & Trailing Shoes for Front & Rear with Auto Brake Shoes Adjuster, ABS 雙迴路全風模式制動, 配合領從式制動蹄片及剎車皮虛位自動調校器, ABS防鎖制車系統				
	Parking Brake 泊車制動	Spring Brake, Action on 2nd & 3rd Axle 彈簧制動第二軸及第三軸				Spring Brake, Action on 2nd & 3rd Axle 彈簧制動第二軸及第三軸		Spring Brake, Action on 3rd & 4th Axle 彈簧制動第三軸及第四軸		
	Auxiliary Brake 輔助制動	Engine Retarder, Exhaust Brake & Easy Smooth Start (ESS) System 引擎制動系統, 廢氣制動及ESS輔助起步系統	Engine Retarder and Exhaust Brake 引擎制動系統及廢氣制動	Engine Retarder, Exhaust Brake & Easy Smooth Start (ESS) System 引擎制動系統, 廢氣制動及ESS輔助起步系統	Engine Retarder and Exhaust Brake 引擎制動系統及廢氣制動	Engine Retarder and Exhaust Brake 引擎制動系統及廢氣制動	Engine Retarder, Exhaust Brake & Easy Smooth Start (ESS) System 引擎制動系統, 廢氣制動及ESS輔助起步系統	Engine Retarder and Exhaust Brake 引擎制動系統及廢氣制動	Engine Retarder and Exhaust Brake 引擎制動系統及廢氣制動	Engine Retarder and Exhaust Brake 引擎制動系統及廢氣制動
Suspension System 懸掛系統	Front 前軸	Semi-Elliptic Tapered Leaf Springs with Shock Absorbers & Stabilizer 半橢圓彈簧片附吸震筒及穩定桿				Semi-Elliptic Leaf Springs with Shock Absorbers 半橢圓彈簧片附吸震筒				
	Rear 後軸	Semi-Elliptic Leaf Springs with 2nd & 3rd axle Shock Absorbers 半橢圓彈簧片附第二軸及第三軸吸震筒				Air Suspension 4 Bellows with Shock Absorbers 氣墊式避震4氣袋附吸震筒		Semi-Elliptic Leaf Springs with 2nd & 3rd axle Shock Absorbers 半橢圓彈簧片附第二軸及第三軸吸震筒		Air Suspension 4 Bellows with Shock Absorbers 氣墊式避震4氣袋附吸震筒
Performance 性能	Gradeability at G.V.W. 爬坡度 (tan)	55.6%	60.0%	55.6%	60.0%	60.0%	47.4%	60.0%	60.0%	60.0%
Tire 輪呔		295 / 80 R22.5				295 / 80 R22.5				
Fuel Tank Capacity 油缸容量		330 (金屬Steel)				330 (金屬Steel)				
Standard Equipment 標準裝置		HID Headlamp with Auto Headlamp Leveling & Washer 高亮度放射式車頭燈連自動角度調校及清洗裝置 Spoiler Type Front Bumper 擾流式前氣把 Driver Seat Airbag 司機位安全氣袋 ISRI Auto Adjustable Air Suspension Driver Seat ISRI自動調節氣墊避震司機座椅 Factory Installed Air-Conditioner (R134A) 原廠安裝R134A環冷暖氣系統 CD Player & AM / FM Radio 鑄射唱碟機及AM/FM收音機 Sleeping Bed with Wrap-around Curtain 睡床連全包围式窗簾 Electrical Tilttable Air Suspension Driver Cab 電動起揚式氣墊避震全浮式駕駛室 Power Windows & Central Door Lock 電動車窗及中央門鎖 Power Mirror Stay 電動摺鏡 Remote Control & Heater Mirrors 電動調校及發熱線倒後鏡 Power Steering 動力輔助轉向系統 Energy Absorbing Steering Wheel 吸撞式軚盤 Collapsible Steering Column 緩衝式軚盤柱 Door Side Impact Beam 車門強化防撞桿 24V-60A Alternator 24伏特-60安培發電機 150Ah Batteries 150安培小時電池 DPR & SCR System 柴油微粒淨化系統及選擇性催化還原器 28L Adblue Tank 28升尿素缸 Aluminium Air Tanks 鋁合金風缸				HID Headlamp with Auto Headlamp Leveling & Washer 高亮度放射式車頭燈連自動角度調校及清洗裝置 Spoiler Type Front Bumper 擾流式前氣把 Driver Seat Airbag 司機位安全氣袋 ISRI Auto Adjustable Air Suspension Driver Seat ISRI自動調節氣墊避震司機座椅 Factory Installed Air-Conditioner (R134A) 原廠安裝R134A環冷暖氣系統 CD Player & AM / FM Radio 鑄射唱碟機及AM/FM收音機 Sleeping Bed with Wrap-around Curtain 睡床連全包围式窗簾 Electrical Tilttable Air Suspension Driver Cab 電動起揚式氣墊避震全浮式駕駛室 Power Windows & Central Door Lock 電動車窗及中央門鎖 Power Mirror Stay 電動摺鏡 Remote Control & Heater Mirrors 電動調校及發熱線倒後鏡 Power Steering 動力輔助轉向系統 Energy Absorbing Steering Wheel 吸撞式軚盤 Collapsible Steering Column 緩衝式軚盤柱 Door Side Impact Beam 車門強化防撞桿 24V-60A Alternator 24伏特-60安培發電機 150Ah Batteries 150安培小時電池 DPR & SCR System 柴油微粒淨化系統及選擇性催化還原器 28L Adblue Tank 28升尿素缸 Aluminium Air Tanks 鋁合金風缸				

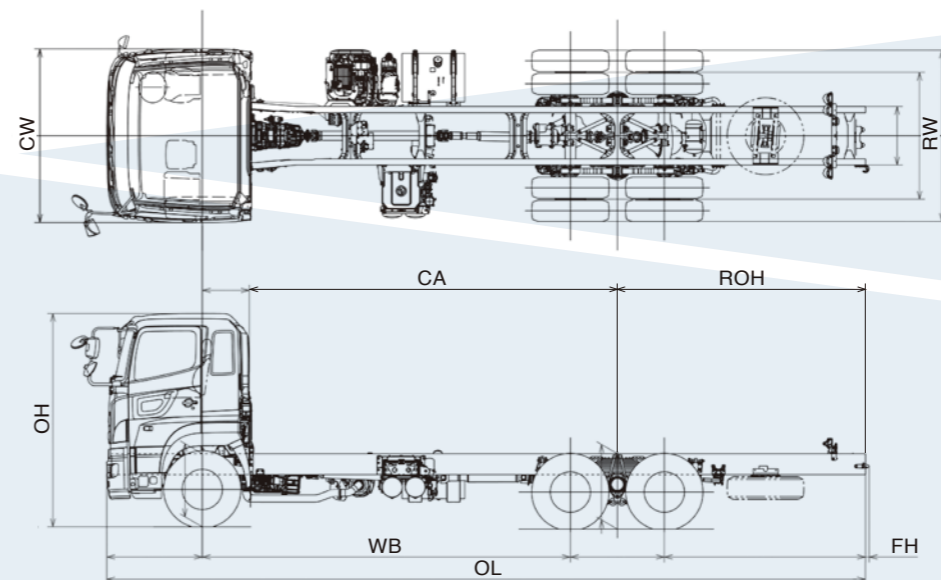
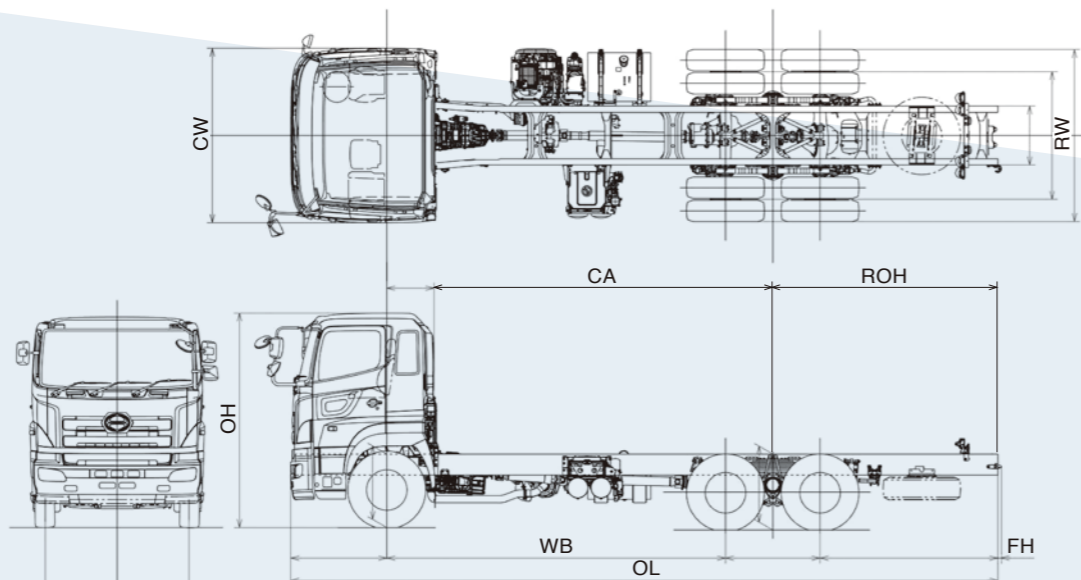

保用
首2年無限公里*

備註：(1) 引擎符合香港現行廢氣及噪音管制條例，詳情請向本公司營業員查詢。
(2) 有關引擎性能及耗油量資料，可向陳列室查詢。
(3) 規格如有更改，恕不另行通知。
(4) 本產品簡介所載之圖片可能與本港出售之型號有差別之處。
* 適用於主要組件，詳情請參閱維修保用證明手冊。

No.1 700系列



運輸-貨車



拖頭

基建-泥頭車

